

# Pipeline

Summer 1997  
Vol. 8, No. 3



Small Community Wastewater Issues Explained to the Public

## Sand Filters Provide Quality, Low-Maintenance Treatment

**T**hanks to a technology that was developed more than 100 years ago, countless homes, schools, businesses, and small communities in rural areas have an alternative to centralized wastewater treatment.

Sand filters treat wastewater using naturally occurring physical, biological, and chemical processes. They are one of the best options for additional onsite treatment where septic tank/soil absorption systems have failed or are restricted due to high groundwater, shallow bedrock, poor soils, or other site conditions. They also can be a good choice for homes, businesses, institutions, and small residential developments and communities in areas where centralized treatment is unavailable or too expensive.

Sand filters usually are used as the second step in wastewater treatment after solids in

raw wastewater have been separated out in a septic tank, aerobic unit, or other sedimentation tank. Wastewater treated by sand filtration is usually colorless and odorless and, depending on local environmental conditions and regulations, sometimes can be disinfected and discharged directly to surface water. When discharged to soil, sand filter effluent can receive further treatment in a soil absorption field, even at some sites where conventional septic tank/soil absorption systems cannot be used.

Over the years, sand filters have proven to be a reliable technology when they are properly designed, constructed, and maintained. Their performance is consistent and they have low operation and maintenance requirements. In addition, overall treatment costs often compare favorably with other alternative systems.

### Why Consider Sand Filters?

#### Small Community Officials:

- Sand filters cost less to construct than centralized treatment systems.
- They are energy-efficient.
- They have low maintenance requirements and often can be operated by part-time staff or volunteers.
- They can provide higher quality treatment than other systems.

#### Homeowners:

- Sand filters may enable development or use of difficult sites.
- They can remedy an existing malfunctioning system.
- They can be a good option for homes in environmentally sensitive areas.

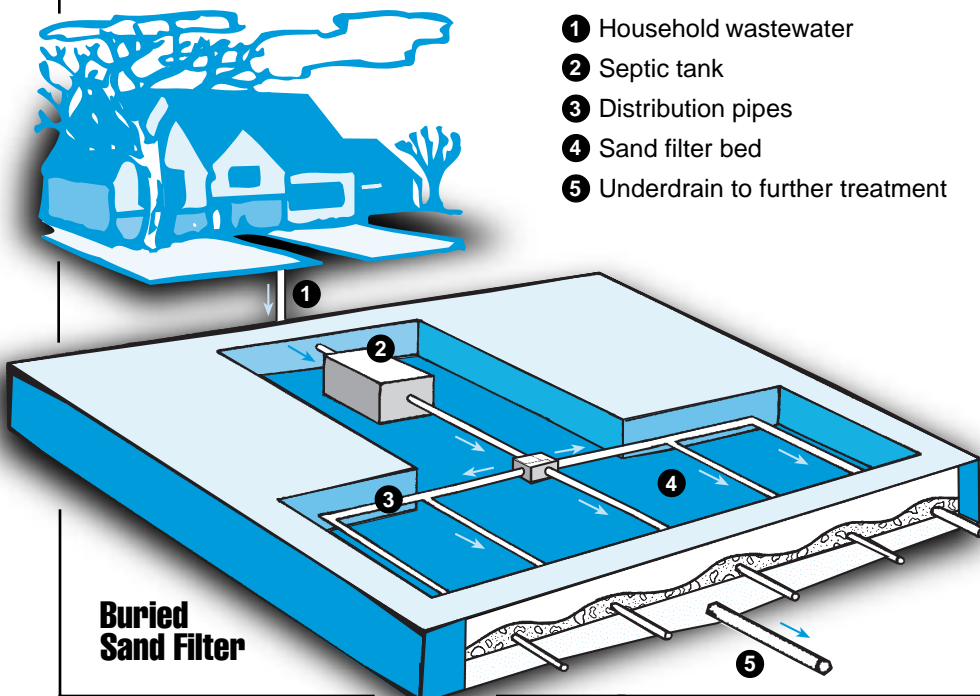

This issue of *Pipeline* provides an overview of three types of sand filters, their design, how they work, and their advantages and disadvantages for homes and small communities. Operation and maintenance issues also are discussed.

Readers are encouraged to reprint *Pipeline* articles in local newspapers or include them in flyers, newsletters, or educational presentations. Please include the name and phone number of the National Small Flows Clearinghouse (NSFC) on the reprinted information and send us a copy for our files.

If you have any questions about reprinting articles or about any of the topics discussed in this newsletter, please contact the NSFC at (800) 624-8301 or (304) 293-4191. 

## How Do Sand Filters Work?

More goes on inside a sand filter than meets the eye. On one hand, sand filters are simple in design and easy to operate and maintain. What is surprising about them are the complex processes that take place in them naturally, which, together, result in wastewater treatment.

### What Are Sand Filters?

Sand filters are constructed beds of sand or other suitable granular material usually two to three feet deep. The filter materials (called media) are sometimes contained in a liner made of concrete, plastic, or other impermeable material. Depending on the design, the filter may be situated above ground, partially above ground, or below ground, and the filter surface may be open or covered.

Partially treated wastewater is applied to the filter surface in intermittent doses and receives treatment as it slowly trickles through the media. In most sand filters, the wastewater then collects in an underdrain and flows to further treatment and/or disposal.

Sand filter units are constructed or assembled onsite by a licensed contractor—preferably one who has specific sand filter experience. Most materials are available locally, sometimes with the exception of filter media. If the appropriate media cannot be obtained nearby, it must be shipped in, which can greatly increase the filter's cost.

Suitable filter media can be purchased from aggregate companies or other suppliers. The media must be as clean and uniform in size as possible to allow the wastewater to flow correctly through it. If not, smaller grains will settle in the spaces between the larger grains, leaving no place for the wastewater to flow. (A typical flow pattern is shown in the graphic on this page.)

There are different sand filter types and designs. Some are better suited for small communities, clusters of homes, large businesses, or institutions, while others are more appropriate for individual homes and small businesses. (A few common sand filter types are described in this issue beginning with the articles on page 3.)

### Sand Filter Basics

There are a few basic operating and design principles common to every type of sand filter system.

First, to prevent the filter from clogging, the wastewater must be pretreated to remove solids and scum. Pretreatment usually takes place in a septic tank, Imhoff tank, or aerobic unit. Screens or filters are sometimes used in the pretreatment tank as an additional step to ensure that no solids carry over to the filter in times of heavy water use.

After the solids have been removed, a pump equipped with an adjustable timing mechanism or a siphon doses the wastewater to the filter in timed intervals or when the tank becomes full. Applications are spaced intermittently to allow the filter media to drain between doses. This ensures that oxygen is introduced in the filter with every dose of wastewater. Oxygen is critical to the biological and chemical treatment processes that take place inside the filter.

It also is important that the wastewater be applied evenly across the filter surface. This is accomplished either by flooding the surface completely with a thin layer of wastewater, or spraying or applying the wastewater evenly through a network of distribution pipes.

### How Treatment Occurs

As the wastewater percolates slowly through the filter media, natural physical, biological, and chemical processes combine to provide treatment. Most treatment occurs in the first 6 to 12 inches of the filter surface.

Some of the organic matter breaks down in the filter. Particles stick to grain surfaces or get caught in crevices or voids on grains or in spaces between grains. In addition, negatively charged grain surfaces can attract positively charged waste particles and bond with them through a process called adsorption. Chemical bonding also takes place as certain particles in the wastewater come in contact with and react with the media.

Probably the most interesting thing about sand filters is that they accomplish much of the treatment through biological processes.

Like the soil in every backyard, sand filters are home to a variety of organisms, many of which contribute to treatment by consuming organic matter in the wastewater.

Bacteria are the most abundant organisms in the filters, and they do most of the work. There are other beneficial life forms found

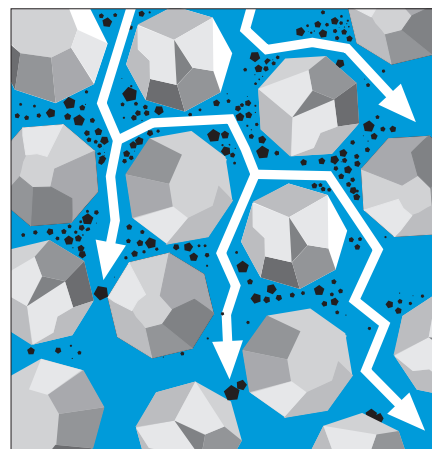

**Typical Flow Pattern Through Filter Media**

in the filters, such as protozoa and worms, which also contribute to treatment.

After the filter has had a chance to mature—usually after a period of approximately two weeks—a miniature ecological system develops as the organisms multiply and rely on each other to survive.

The most significant part of the filter ecosystem is a thick layer called the biomat, which eventually forms near the surface of the filter. This layer contains bacteria which consume particles in the wastewater. In turn, protozoa feed on the bacteria and help prevent the biomat from becoming so dense that it clogs the filter. This balance between the various life forms and the physical and chemical processes that take place in the sand filter results in extremely efficient wastewater treatment requiring minimal operation and maintenance.

Eventually, the biomat in some filters does become clogged, and the top layer of sand needs to be raked or removed as part of regular filter maintenance. 💧

# Common Sand Filter Designs

**S**and filters are a versatile technology and there are many possible sand filter system designs. Intermittent sand filters receive and treat wastewater in doses. Three of the most common types of sand filters—buried, open, and recirculating—are intermittent designs. (See page 5 for a discussion of recirculating sand filters.)

## Buried Sand Filters

The most common sand filters used for homes, small businesses, and other small flows require little maintenance and work completely underground.

Buried sand filters are constructed onsite and usually require an excavation of four

to five feet. Before construction, a thorough site evaluation is needed to ensure the filter bed will be level. The filter also must be sited to avoid contact with groundwater and excess surface water runoff. (Refer to the graphic on page 1 for an example of a buried sand filter.)

Depending on local regulations and site conditions, the entire buried filter unit may be contained in an impermeable membrane liner. Underdrain pipes and a graded layer of washed gravel or crushed rock are placed at the bottom of the filter bed—with the finer gravel on top of the coarser gravel to keep the media grains from washing into the underdrains.

The filter media is then placed on top of the layer of fine gravel. As with all sand filters, the depth of the media depends on the size of the grains and other factors, but normally ranges from 24 to 36 inches.

Another graded layer of gravel is placed on top of the media bed and surrounds a network of distribution pipes. However, the order is reversed this time and the finer gravel is placed under the coarser gravel closest to the media bed. A geotextile fabric is placed on top of the entire filter bed and then is covered with backfill material.

Most buried sand filters are dosed twice a day or as often as is naturally dictated by

Continued on page 4

## Many Factors Affect Sand Filter Performance

### Pretreatment

Pretreatment is very important to sand filter performance. Solids in the wastewater must be removed by some method of pretreatment or primary treatment or else they will clog the filter. Septic tanks, aerobic units, screens, and other pretreatment methods should operate properly and receive regular maintenance.

Septic tanks are the most common and usually the least expensive pretreatment method for sand filters.

### Media

The composition, size, uniformity, and depth of the media all affect sand filter performance.

In some areas where sand is not available locally, other materials, such as crushed glass, anthracite, garnet, mineral tailings, or bottom ash, have been used for filter media. Characteristics of the media's composition, such as its solubility, acidity, and hardness, must be considered in the filter design. It also is extremely important that the media be washed. It should be inspected for cleanliness by an engineer or other qualified individual before it is used in the filter.

The size and uniformity of the grains also affect performance, filter depth, and the amount of wastewater that can be treated at one time.

The media grains are sorted and measured through a series of mechanical

sieves. The grains should be relatively uniform in size to prevent clogging. "Effective size" and "uniformity coefficient" are measurements used to express these characteristics. Effective sizes for sand filter media range from 0.3 mm to 3 mm in diameter. Each sand filter type has its own media size range requirements. (Refer to the table on page 4 for more information.) A uniformity coefficient of four or less is recommended for all filter media.

In addition, the media should be neither too coarse nor too fine. Coarse media may allow wastewater to pass too quickly through the filter without receiving adequate treatment, while very fine media can slow down treatment too much, is prone to clogging, and can keep oxygen from reaching certain parts of the filter.

Filter depth depends on the type of filter and media size, but normally ranges from 24 to 36 inches. Most treatment occurs in the first 6 to 12 inches, but a few additional inches improves overall performance, pathogen removal, and allows for maintenance.

### Organic Loading Rate

Organic loading rate depends on the strength of the wastewater. Depending on its source, wastewater may contain more or less organic material requiring treatment. Strong wastewater containing high levels of organic material can reduce the filter's performance over time and increase the need for maintenance.

### Hydraulic Loading Rate

Hydraulic loading rate is the amount of wastewater applied to the filter in one day. Sand filters are less effective at removing certain pathogens and other wastes from wastewater at high hydraulic loading rates. The appropriate rate is determined based on the dosing pattern, the size of the media, and the organic loading rate.

### Dosing Method and Frequency

Careful dosing and even distribution of the wastewater across the filter surface are needed to ensure consistent treatment. Uneven distribution may cause one part of the filter to become overloaded, and wastewater can be flushed through the filter before receiving adequate treatment. Too frequent dosing causes similar problems. Doses should be spaced to allow the filter adequate time to drain and reerate.

### Climate and Temperature

All wastewater treatment methods that rely on natural processes are affected by temperature. Treatment slows down in cold temperatures, so organic loading rates must be lower to maintain treatment. Freezing also can be a problem with certain filter designs, such as recirculating filters and open filters, and some designs may be inappropriate for cold climates. Sometimes adjusting hydraulic loading rates and dosing frequencies can help filter performance in low temperatures. 💧

# Common Sand Filter Designs

Continued from page 3

household water use. After the wastewater receives treatment, it collects in the underdrains and then usually either flows to disinfection in a chlorination unit and to surface discharge or directly to a soil absorption field for further treatment and subsurface discharge.

The underdrains are sloped toward the outlet and vented at the surface at the upstream end. If possible, the surface vent should be located away from residences to minimize possible odor problems.

Buried sand filters are designed to

receive hydraulic loads of approximately 1.2 to 1.5 gallons per square foot per day. This is a relatively low rate compared with other sand filters, which helps to ensure that the filter does not become overloaded or clogged and that it can work up to 20 years without maintenance.

Due to this low hydraulic loading rate, buried filters usually require more surface area to treat the same amount of wastewater as other sand filters. However, with good landscaping techniques, the land used for buried sand filters can be available for other aesthetic uses.

And, although the filter itself does not require maintenance, regular maintenance is essential for the septic tank or other pretreatment tank to prevent solids from clogging the filter. (Refer to the sidebar on page 6.) Maintenance is also important for screens, pumps, siphons, timers, disinfection units, and components of soil absorption fields.

## Open Sand Filter

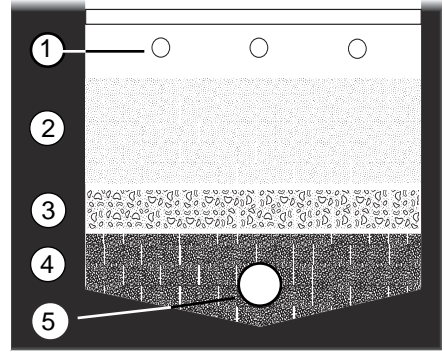

- ① Distribution pipes
- ② Filter media
- ③ Fine gravel
- ④ Coarse gravel
- ⑤ Underdrain

Because the filter surface is accessible and easy to maintain, open sand filters are more practical than buried filters for treating large volumes of wastewater. Hydraulic loading rates for open filters typically range from two to five gallons per square foot per day and could be higher in some cases.

In addition, open filters usually have two or more beds that can be operated in parallel or in series, which allows parts of the filter to be rested while others are working.

In spite of their name, many open sand filters have removable covers to insulate them from extreme cold weather, minimize maintenance, and reduce odors, which can be a nuisance.

Because odors are generated when septic tank effluent is dosed to the filter surface, open sand filters should be sited downwind from residences and businesses. Where this is impractical, other options should be considered, such as using a recirculating sand filter. 💧

## How Well Do Sand Filters Perform?

Depending on the system design, sand filters are capable of reducing five-day biochemical oxygen demand (BOD<sub>5</sub>) and total suspended solids (TSS) in wastewater to 10 milligrams per liter or less.

Both BOD<sub>5</sub> and TSS are indicators used by regulatory agencies to assess treatment and its potential impact on the environment. BOD<sub>5</sub> is a measure of the amount of oxygen microorganisms need to consume and break down organic matter. TSS is a measure of the amount of waste particles suspended in the wastewater.

Sand filters also remove many pathogens, such as viruses and harmful bacteria. However, disinfection or further treatment may be necessary before the effluent can safely be returned to the environment.

One disadvantage of sand filters is that they are not very effective at removing phosphorus from wastewater. Therefore, additional treatment may be required in some phosphorus sensitive areas.

Sand filters are not permitted in all areas. Regulations concerning their use and final treatment and disposal of their effluent vary widely. Check with your local health department or state regulatory agency for permit requirements in your area. (Refer to page 7 for contact information.) 💧

## Open Sand Filters

Open sand filters—which are often simply called intermittent sand filters—are a practical option for treating wastewater from small communities, residential developments, recreational areas, shopping centers, and institutions. They are used most often for sources generating up to 120,000 gallons of wastewater per day.

Open sand filters are similar in design to buried sand filters, except they always are at least partially above ground. Depending on local regulations, site conditions, and the size of the filter, they may be contained in an impermeable synthetic liner or concrete. (Refer to the graphic above for an example of an open sand filter design.)

### Typical Design Values For Sand Filters\*

Design Factor	Buried	Open	Recirculating
Pretreatment	Must include settling/removal of solids		
Media	Washed, Durable Granular Material		
Material			
Effective size	0.3–1 mm	0.3–1 mm	0.8–3 mm
Unif. Coeff.	<4.0	<4.0	<4.0
Depth	24–36 inches	24–36 inches	24–36 inches
Hydraulic Loading	<1.5 gpd/ft <sup>2</sup>	2–5 gpd/ft <sup>2</sup>	3–5 gpd/ft <sup>2</sup> (based on forward flow only)
Organic Loading	<5 x 10 <sup>-3</sup> lbs. BOD <sub>5</sub> /day/ft <sup>2</sup>		
	<2.4 x 10 <sup>-2</sup> kg. BOD <sub>5</sub> /day/m <sup>2</sup>		
Media Temperature	>5° C	>5° C	>5° C
Dosing Frequency	<2 per day	>2 per day	5–10 min./30 min.
Recirculation Ratio	NA	NA	3:1 to 5:1

\*The values above only show typical design criteria for sand filters and do not represent all possibilities. Adapted from: Anderson et al. 1985. "Technology Assessment of Intermittent Sand Filters." U.S. Environmental Protection Agency.

## Recirculating Sand Filters: An Innovative Solution

In the late 1960s, two engineers with the Illinois Department of Health, Michael Hines and R. E. (Tony) Favreau, set out to solve a common problem facing their area. Although sand filters were the best treatment option for many local sites with poor soils or other limiting conditions, the odors associated with them made them unsuitable for more developed areas.

In response to this challenge, the two developed an innovative sand filter design—the recirculating sand filter—which has been widely adapted and used ever since for schools, homes, businesses, recreational areas, and small communities.

Recirculating sand filters eliminate odors by ensuring an adequate supply of oxygen to the wastewater. (Refer to the graphic below for an example of a recirculating sand filter design.)

The ratio of sand filter effluent that is recirculated ranges from 3:1 to 5:1. How this amount is controlled varies with individual system designs. Weirs, moveable gates, and other devices can be used to direct part of the flow from the sand filter underdrains to the recirculation tank.

In the example shown in the graphic below, an upside-down tee pipe in the recirculation tank connects to the sand filter underdrains. A rubber ball in a screened cage rises with the water in the tank and plugs the tee when the tank reaches a certain level. When this happens, the remaining sand filter effluent bypasses the recirculation tank and flows directly on to disinfection or further treatment and/or disposal.

However recirculation is achieved, the result is that the wastewater applied to the

### Recirculating Sand Filter

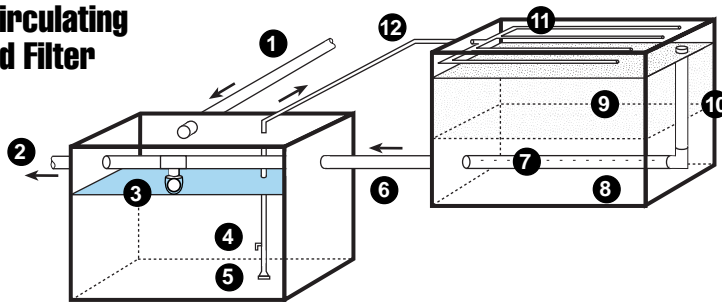

- |                             |                                 |
|-----------------------------|---------------------------------|
| 1 From pretreatment         | 7 Perforated underdrain piping  |
| 2 To disinfection/discharge | 8 Layered support gravel        |
| 3 Float valve               | 9 Filter media                  |
| 4 Bleed line                | 10 Riser pipe                   |
| 5 Submersible pump          | 11 Distribution piping          |
| 6 Filter effluent line      | 12 Recirculation pump discharge |

In a recirculating sand filter, wastewater flows by gravity from a septic tank to a recirculation tank, which is equipped with a pump, a timing mechanism, and float valves. The wastewater is pumped to the filter when the wastewater reaches a certain level in the tank or in timed doses.

After receiving treatment in the sand filter, the wastewater collects in underdrains and a portion of it is directed back to the recirculation tank, where it mixes with the septic tank effluent and is recirculated to the sand filter. The remaining sand filter effluent bypasses the recirculation tank and goes directly to disinfection or further treatment.

sand filter is weaker and contains more oxygen than straight septic tank effluent, which eliminates odors. The final sand filter effluent also is of higher quality and ranges from 2 to 5 mg/L BOD, and from 3 to 5 mg/L TSS.

Recirculating sand filter media ranges from an effective size of 0.8 mm to 3 mm, which is somewhat coarser than other sand filter media and, therefore, less prone to clogging. Hydraulic loading rates typically range from three to five gallons per square foot per day, meaning that less land area is generally needed to treat the same amount of wastewater than with other sand filter designs. Energy and routine maintenance



### How Much Do Sand Filters Cost?

Exact costs for sand filter construction, operation, and maintenance depend on the filter design and local costs for labor and materials. Costs for pretreatment and additional treatment and disposal also need to be factored in when evaluating the overall system costs.

Construction of the sand filter units themselves usually is economical because the filters can be constructed or assembled onsite using local labor and materials. Another advantage is their low operation and maintenance requirements. Operating costs are limited to the small amount of electricity used by the pump (usually around 0.28 horsepower per hour per 1,000 gallons), and most maintenance can be performed by homeowners or unskilled staff.

The two most significant factors that affect the cost of sand filter treatment are land and media costs. In areas where media is expensive or needs to be hauled a long distance, costs are much higher.

Initial costs for sand filters are sometimes higher than those for extended aeration package plants and other treatment options. However, in the long-run, sand filters' low energy costs, low operating costs, and high performance often make them the most cost-effective choice. 💧

requirements are more than for other sand filters but are still minimal and much less than is required for extended aeration package plants.

One drawback to recirculating sand filters is they are more sensitive to cold temperatures and prone to freezing than systems that are regularly dosed with warm septic tank effluent. This problem sometimes can be offset by adjusting the dosing frequency and the recirculation ratio or by covering the sand filter bed. 💧

## Sand Filters Are Simple to Operate, Maintain

### Pretreatment Tanks Need Maintenance Too

Sand filters performance depends on pretreatment tanks working properly. The following *Pipeline* issues contain useful information about the siting, design, construction, installation, operation, and maintenance of septic tanks and aerobic units—two common pretreatment methods for sand filter systems.

- Summer 1995 *Pipeline*: "Septic Systems: A Practical Alternative for Small Communities."  
Item # **SFPLNL02**.



- Fall 1995 *Pipeline*: "Maintaining Your Septic System: A Guide for Homeowners."  
Item # **SFPLNL03**.

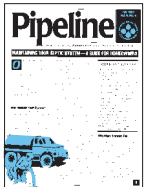

- Winter 1996 *Pipeline*: "Home Aerobic Wastewater Treatment: An Alternative To Septic Systems."  
Item # **SFPLNL04**.

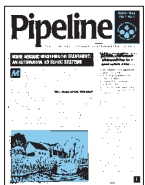

*Pipeline back issues can be ordered from the National Small Flows Clearinghouse (NSFC) for \$0.20 each plus shipping and handling by calling (800) 624-8301 or (304) 293-4191, fax (304) 293-3161, or e-mail [nscf\\_orders@estd.wvu.edu](mailto:nscf_orders@estd.wvu.edu). Please request each item by number and title.*

*Pipeline is available online at NSFC's website at <http://www.nscf.wvu.edu>.*

Most operation and maintenance requirements for open and recirculating sand filter beds are simple and can be performed by homeowners, unskilled staff, or volunteers. Exactly how much maintenance is needed varies by system design and can be best determined after working with the filter over a period of a year or more. Buried sand filter beds are the exception and can work up to 20 years without maintenance.

Routine maintenance of open and recirculating sand filter beds includes periodic leveling and raking the surface and raking or removing the surface layer when it begins to clog. How often clogging occurs will depend on organic loading rates and the filter media size.

For example, sand filters receiving septic tank effluent may need more frequent attention than those receiving aerobic unit effluent, because the organic strength of the septic tank effluent is higher. In addition, because recirculating sand filters use coarser media and receive lower organic loading rates, they tend to clog less frequently.

Sometimes simply raking the filter surface will not suffice and the top half-inch to one-inch layer of media must be removed. Most sand filters are designed to be deep enough to allow several layers to be removed before the media needs to be replenished or replaced.

Filter beds that are exposed to sunlight should be weeded regularly and may develop algal mats that need to be removed.

Maintenance for other parts of the system may include periodic inspection and service by a qualified professional. For example, pretreatment tanks and disinfection units need to be inspected and pumped, and electrical components, such as pumps and timers need to be checked and serviced according to manufacturer recommendations.

Pumps often are designed to last from 10 to 25 years, but eventually need to be replaced. Pipes, valves, and other system components need to be checked regularly, and screens and filters need to be cleaned. (*Refer to the sidebar at left and the table below for more information.*)

Many larger sand filters are operated in sections to allow portions of the filter bed to rest by switching the sections to be dosed. It also is sometimes necessary to regulate hydraulic loading rates to prevent the filter from being overloaded or to prevent the filter surface from freezing.

Another cold-weather operating strategy entails raking the filter bed in a pattern of ridges and furrows and flooding the surface until an ice sheet forms. The filter can then be loaded below the insulating sheet of ice.

General maintenance requirements for both open and recirculating sand filters are summarized in the table below. 💧

### Sand Filter Maintenance

Item	Requirement
Pretreatment	Depends on process (septic tank, aerobic unit, etc.)
Dosing chamber	
Pumps and controls	Check every 3 months.
Timer sequence	Check and adjust every 3 months.
Appurtenances	Check every 3 months.
Filter media	
Raking	Check every 3 months. If drainage time between doses has increased significantly, rake top 3 in. (for surface filters only).
Replacement	Skim media when heavy incrustations occur. Add new media when depth falls below 24 in. Rest when ponded continuously. Replace top 2–3 in. media when surface ponds more than 12 in. deep. Rest while alternate unit in operation (60 days).
Other	
	Weed as required.
	Maintain distribution device as required.
	Protect against ice sheeting.
	Check high water alarm (for open sand filters only).

Adapted from: U.S. Environmental Protection Agency, 1980. Design Manual: Onsite Wastewater Treatment and Disposal Systems.

## Maryland County Explores New Filter Designs

Anne Arundel County, Maryland, has hundreds of miles of shoreline along the Chesapeake Bay and its tributaries. In this environmentally sensitive area, homes on very small lots using septic systems are common. Many sites have soils that are slowly permeable with high groundwater levels.

In 1987, the county began using small recirculating sand filters that produce a high-quality effluent with reduced nitrogen levels. Since then, more than 250 recirculating filters have been installed at local residences.

"The use of recirculating sand filters for individual homes has been very challenging," explains Richard Piluk, an engineer with Anne Arundel County who designed many of the systems. "Our goal is to ensure a high level of wastewater treatment for the area by designing systems that are appropriate for local site conditions and that require very little maintenance on the part of the homeowner."

To achieve this goal, the county has experimented with several innovative design features for recirculating sand filters. For example, the surface area of a typical single-residence recirculating filter in Anne Arundel County is only 45 square feet, making it suitable for small lots. In addition, most of the filter units are above-ground in concrete liners to allow

recirculation and gravity flow to shallow soil absorption fields with the use of a single pump.

Originally, all of the filters were designed to use sand media with an effective size of 1 mm. However, recent filters are using an experimental expanded shale media with an approximate size of 9 mm. The coarser media provides similar treatment and should be less prone to clogging.

"The expanded shale also weighs much less than the sand," says Piluk. "Because of this, we are now designing a filter unit for individual homes that can be completely constructed and assembled off-site using precast concrete containers. The lighter media makes it feasible to load the whole unit on a truck for delivery to the site."

This newest innovation could translate into substantial savings, not only for local residents, but for homeowners in every part of the country.

Other innovative features with potential national relevance are being monitored in residential systems in Anne Arundel County as part of the National Onsite Demonstration Project (NODP). Data from the demonstration sites will be included in a report to Congress later this year.

*For information about the NODP, contact the National Small Flows Clearinghouse at (800) 624-8301 or (304) 293-4191. 💧*

## NSFC Resources Provide Latest Information

The National Small Flows Clearinghouse (NSFC) continuously updates its databases and other resources to provide the latest information about sand filters and other wastewater technologies and issues.

The NSFC's [Manufacturers/Consultants Database](#), for example, recently was reorganized to make it more useful and efficient for callers, who can now request searches by more of 80 products or 34 service categories, including sand filters. Homeowners, community officials, and engineers who want up-to-date information about local sand filter manufacturers, suppliers, and consultants who specialize in sand filters can contact NSFC and order a customized search of the database.

Another valuable resource at NSFC is the [Bibliographic Database](#). New research

from periodicals is always being added to the database, and callers can request searches for abstracts of the latest articles on sand filters and other subjects.

The NSFC also offers an updated [Contacts and Referrals](#) list of agencies, organizations, and programs that provide a variety of assistance and services to small communities concerning wastewater projects.

In addition, the NSFC maintains a [Facilities Database](#), which provides communities with contacts and information about other communities using specific wastewater systems or technologies.

*For more information about the NSFC's resources or to request a customized database search, contact an NSFC technical assistance specialist at (800) 624-8301 or (304) 293-4191. 💧*

## CONTACTS



### National Small Flows Clearinghouse (NSFC)

The NSFC offers a variety of technical assistance and free and low-cost information and materials about wastewater technologies for small communities. Just a few of the NSFC's many resources and services are mentioned in this newsletter. Call the NSFC at (800) 624-8301 or (304) 293-4191 for more information.

### Local Health Departments

Residents of small communities interested in sand filters and other wastewater systems should contact their local health departments for more information about local regulations and requirements. Health departments are usually listed in the government section or blue pages of local phone directories.

### Extension Service Offices

Many universities have U.S. Department of Agriculture Extension Service offices on campus and in other locations that provide a variety of services and assistance to small communities. Contact the NSFC for the number of the office in your area, or call the U.S. Department of Agriculture at (202) 720-3377.

### Rural Community Assistance Program (RCAP)

RCAP is a network of nonprofit organizations that provide assistance to rural and low-income communities concerning almost every aspect of planning wastewater projects. Call RCAP's national office at (703) 771-8636 or the NSFC for the number of your regional RCAP office.

### National Rural Water Association (NRWA)

NRWA is a nonprofit association organized to represent small water and wastewater utilities in each state and to meet their needs with operation, maintenance, management, funding, and political concerns. It offers a variety of assistance and services. Contact the NSFC for the number of your state RWA office. 💧

# RESOURCES AVAILABLE FROM NSFC

To order products listed as available from the National Small Flows Clearinghouse (NSFC), call (800) 624-8301 or (304) 293-4191, fax (304) 293-3161, e-mail [nsfc\\_orders@estd.wvu.edu](mailto:nsfc_orders@estd.wvu.edu), or write NSFC, West Virginia University, P.O. Box 6064, Morgantown, WV 26506-6064. Please request each item by number and title. A shipping and handling charge will apply.

## New Onsite Systems Report Available

In 1994, the NSFC began a massive effort to request information from as many local onsite and health agencies as possible about the status of onsite systems. Approximately 3,500 agencies were contacted, and their responses have been compiled in a new report: *National Onsite Wastewater Treatment: A National Small Flows Clearinghouse Summary of Onsite Systems in the United States, 1993*.

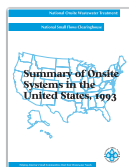

The 414-page report includes information about the types and number of new onsite systems permitted, reasons for permit denial, permit costs, construction/installation costs, inspection and maintenance practices, and reasons for system failures.

Local agencies identified system age, unsuitable soils, lack of maintenance, high groundwater, and excessive water use as the most common problems leading to onsite system failure. The price is \$17.50. Item #WWBKGN89.

## Onsite Wastewater Treatment and Disposal Systems

Published by the U.S. Environmental Protection Agency (EPA), this 410-page design manual contains important technical information about several onsite technologies including sand filters and soil absorption fields. The price is \$45.00. Item #WWBKDM35.

## Sand Filter Technology Package

This newly updated package provides an overview of sand filter design and use. A case study, technology assessment, and cost comparisons are included. The price is \$12.10. Item #WWBKGN29.

## Computer Search on Sand Filters

NSFC's Bibliographic Database contains abstracts of more than 250 articles on sand filter design, costs, operation and maintenance, performance, and other related issues. Many articles are available through the NSFC. (Call the NSFC for price.) Item #WWBLCM08.

## EPA Technology Assessment of Intermittent Sand Filters

Information about sand filters and their design, capabilities, limitations, costs, operation, and maintenance is included in this EPA document. Comparisons with equivalent technologies also are offered. The price is \$4.50. Item #WWBLDM20.

## Video: Sand Filter Technology

This video describes buried, open, and recirculating sand filters and their advantages, design, costs, operation and maintenance. The price is \$10.00. Item #WWVTPE03.

## PIPELINE

*Pipeline* is published quarterly by the National Small Flows Clearinghouse at West Virginia University, P.O. Box 6064, Morgantown, WV 26506-6064. <http://www.nsfc.wvu.edu>

### *Pipeline* is sponsored by:

U.S. Environmental Protection Agency  
Washington, D.C.  
Steve Hogue—*Project Officer*  
Municipal Support Division  
Office of Wastewater Management

National Small Flows Clearinghouse  
West Virginia University  
Morgantown, WV  
Peter Casey—*Program Coordinator*  
Diana Knott—*Acting Publications Supervisor*  
Clement Solomon—*Special Technical Advisor*  
Cathleen Falvey—*Editor*  
Daniel Gloyd—*Graphic Designer*

Permission to quote from or reproduce articles in this publication is granted when due acknowledgement is given. Please send a copy of the publication in which information was used to the *Pipeline* editor at the address above.

ISSN: 1060-0043

*PIPELINE* is funded by the United States Environmental Protection Agency. The contents of this newsletter do not necessarily reflect the views and policies of the Environmental Protection Agency, nor does the mention of trade names or commercial products constitute endorsement or recommendation for use.

Printed on recycled paper

For wastewater information, call the NSFC at 1-800-624-8301 or (304) 624-8301.



National Small Flows Clearinghouse  
West Virginia University  
P.O. Box 6064  
Morgantown, WV 26506-6064

ADDRESS CORRECTION REQUESTED

Nonprofit Organization  
U.S. Postage Paid  
Permit No. 34  
Morgantown, WV